



TOWER HOBBIES

EXTRA SPECIAL .40™

RADIO CONTROLLED MODEL AIRPLANE KIT
INSTRUCTION MANUAL

Wing Span: 44 in.
Wing Area: 627 sq. in. Weight: 3.5 lb.
Length: 34.5 in. Wing Loading: 13 oz./sq. ft.
Engine: .35 to .51 Radio: 4 ch./5 servos



The Profile Alternative

ENTIRE CONTENTS © 1997 Version 1.0

PRINTED IN USA 3005173

READ THROUGH THIS INSTRUCTION MANUAL FIRST. IT CONTAINS IMPORTANT INSTRUCTIONS AND WARNINGS CONCERNING THE BUILDING AND USE OF THIS MODEL.

WARRANTY

Tower Hobbies guarantees this kit to be free from defects in both material and workmanship at the date of purchase. This warranty does not cover any component parts damaged by use or modification. **In no case shall Tower Hobbies' liability exceed the original cost of the purchased kit.** Further, Tower Hobbies reserves the right to change or modify this warranty without notice.

In that Tower Hobbies has no control over the final assembly or material used for final assembly, no liability shall be assumed nor accepted for any damage resulting from the use by the user of the final user-assembled product. By the act of using the user-assembled product, the user accepts all resulting liability.

If the buyers are not prepared to accept the liability associated with the use of this product, they are advised to return this kit immediately in new and unused condition to Tower Hobbies.

Your **EXTRA SPECIAL .40** is not a toy, but rather a sophisticated, working model that functions very much like an actual airplane.

Because of its performance, the EXTRA SPECIAL .40, if not assembled and operated correctly, could possibly cause injury to yourself or spectators and damage property.

To make your R/C modeling experience totally enjoyable, we recommend that you get experienced, knowledgeable help with assembly and during your first flights. You'll learn faster and avoid risking your model before you're truly ready to solo.

You can contact the national Academy of Model Aeronautics (AMA), which has more than 2,300 chartered clubs across the country. Through any one of them, instructor training programs and insured newcomer training are available.

Contact the AMA at the address or toll-free phone number below.



Academy of Model Aeronautics

5151 East Memorial Drive

Muncie, IN 47302-9252

Tele. (800) 435-9262

Fax (765) 741-0057

Web Site: [HTTP://WWW.MODELAIROCRRAFT.ORG](http://WWW.MODELAIROCRRAFT.ORG)

TABLE OF CONTENTS

| | |
|---|---|
| <p>ITEMS REQUIRED FOR COMPLETION4</p> <p>SUPPLIES4</p> <p>TOOLS4</p> <p>DIE PATTERNS5</p> <p>IMPORTANT BUILDING NOTES6</p> <p>BUILD THE FUSELAGE, FIN & RUDDER7</p> <p>BUILD THE HORIZONTAL STABILIZER & ELEVATORS11</p> <p>BUILD THE WING & AILERONS12</p> <p>FINAL ASSEMBLY19</p> <p>BALANCE THE AIRPLANE Laterally20</p> <p>COVERING & FINISHING20</p> <p style="padding-left: 20px;">Repairing surface dings20</p> <p style="padding-left: 20px;">Final sanding20</p> <p style="padding-left: 20px;">Cover the structure with TowerKote™20</p> <p style="padding-left: 20px;">Recommended covering sequence21</p> <p>FINAL HOOKUPS AND CHECKS21</p> | <p>BALANCE YOUR MODEL24</p> <p>CONTROL SURFACE THROWS25</p> <p>PREFLIGHT26</p> <p style="padding-left: 20px;">Balance the propeller26</p> <p style="padding-left: 20px;">Charge the batteries26</p> <p style="padding-left: 20px;">Ground check the model26</p> <p style="padding-left: 20px;">Range check your radio26</p> <p>SAFETY PRECAUTIONS26</p> <p>FLIGHT27</p> <p style="padding-left: 20px;">Takeoff27</p> <p style="padding-left: 20px;">Flying27</p> <p style="padding-left: 20px;">Landing28</p> |
|---|---|

3

Congratulations!

If you have been looking for a way to put the *FUN* back into your Sunday flying, you have just found it. The EXTRA SPECIAL .40 is a nimble little *profile hot-dogger* that assembles in only a few hours and is easy on the budget. It does not require any special building or flying skill - just a few hand tools and a little tail-dragger time. With its oversized control surfaces it turns, loops and rolls in the blink of an eye. But the thick, high lift airfoil and light wing loading allow the plane to slow way down for gentle spot landings. If equipped with an engine like the Tower .40 it's possible to be airborne in a matter of feet, zip through three rolls, loop on its own axis, then go into the "hover" mode while waiting for your buddies to get off the ground. What more can we say? The EXTRA SPECIAL .40 maximizes fun for minimal cost and time!

ITEMS REQUIRED FOR COMPLETION

We strongly recommend using Great Planes® and Tower accessories for all your modeling needs.

- 4 Channel radio with 5 servos and a Y-harness (TOWJ40**) (TOWM4520 x 5)
- .35 - .51 2/S or .40 - .52 4/S engine (Tower .40 ABC ideal)
- 4 - 6 oz. Fuel tank (GPMQ4101) or (GPMQ4102)
- (2) 2-1/2" Wheels (GPMQ4223)
- 1" Tail wheel (GPMQ4241)
- (2) 3/32" Wheel collars (GPMQ4302)
- 12" Medium fuel tubing (GPMQ4131)

- (2) Rolls covering film
- 1/4" Foam rubber (HCAQ1000)
- 2-1/2" Spinner (GPMQ4522 Red)

SUPPLIES

- 1 oz. Thin CA (GPMR6002)
- 1 oz. Medium CA (GPMR6008)
- 6-minute epoxy (TOWR3300)
- 30-minute epoxy (TOWR3350)
- Balsa filler (HCAR3401)
- Masking tape (GPMR1010)
- Wax paper
- Isopropyl rubbing alcohol (70%)
- Microballoons

TOOLS

- Sanding block and sand paper (coarse, medium, fine)
- Hobby knife and #11 blades (TOWR1010) (TOWR1015)
- Single edge razor blades (TOWR1005)
- Razor saw
- Razor plane
- Electric drill
- Drill bits - 1/16", 1/8", 5/32"
- Small Phillips and flat blade screwdrivers
- Pliers with wire cutter
- Sealing iron and heat gun (TOWR3250) (TOWR3200)
- T-Pins (HCAR5150)
- Straightedge with scale

4

DIE PATTERNS

3/32" X 3" X 18" Balsa

2 PER KIT

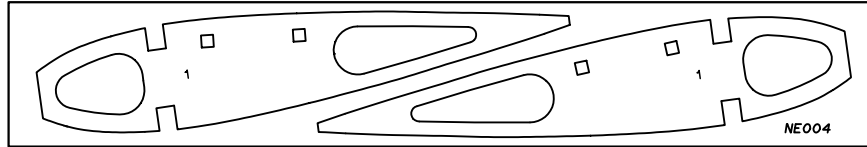

NE004

3/32" X 3" X 18" Balsa

5 PER KIT

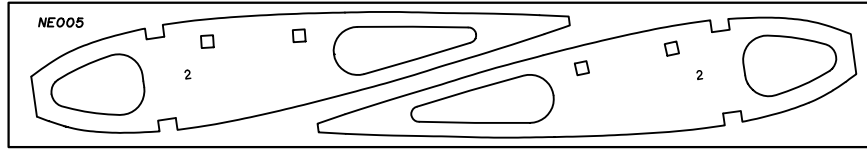

NE005

1/8" X 5-5/8" X 20" Ply

2 PER KIT

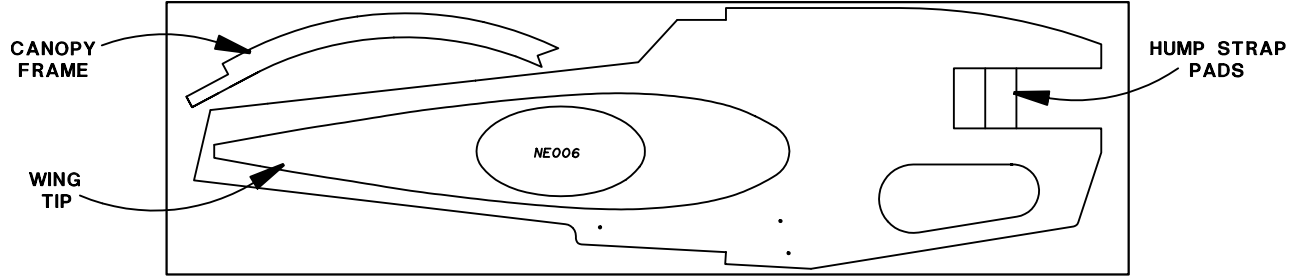

NE006

5

We, as the kit manufacturer, provide you with a top quality kit and great instructions, but ultimately the quality and flyability of your finished model depends on how you build it; therefore, we cannot in any way guarantee the performance of your completed model, and no representations are expressed or implied as to the performance or safety of your completed model.

Remember: Take your time and follow directions to end up with a well-built model that is straight and true.

Please inspect all parts carefully before starting to build! If any parts are missing, broken or defective, please call us at (800) 637-6050 (Outside the USA - (217) 398-3636) and we'll be glad to help.

IMPORTANT BUILDING NOTES

Unroll the plan sheets, then reroll the plans inside-out to make them lie flat.

Sort through the sticks and sheets, grouping them by size. Masking tape can be used to bundle matching sheets and sticks. Using a felt tip or ball point pen, lightly write the part **name** or **size** on each piece or bundle. Refer to the parts list and plans for sizes and quantities. Use the die-cut patterns shown on page 5

to identify the die-cut parts and mark them **before** removing them from the sheet. Save all scraps. If any of the die-cut parts are difficult to remove, do not force them! Instead, cut around the parts with a hobby knife or lightly sand the back of the sheet. After removing the die-cut parts, use your sanding block to **lightly** sand the edges to remove any die-cutting irregularities.

Work on a flat surface. Cover the plans with wax paper or Great Planes plan protector (GPMR6167). There are notes on the plans that tell you what material to use to make each part.

When instructed to *test fit* parts, this means **DO NOT USE GLUE** until you are satisfied that everything fits properly – THEN glue the parts together when instructed to do so.

The easiest way to cut balsa sticks is with a single edge razor blade or razor saw. Position the stick over the plan, mark its size and then cut the part on a piece of scrap lumber. A modeling miter box works well for cutting square corners and 45 degree gussets.

6

BUILD THE FUSELAGE, FIN AND RUDDER

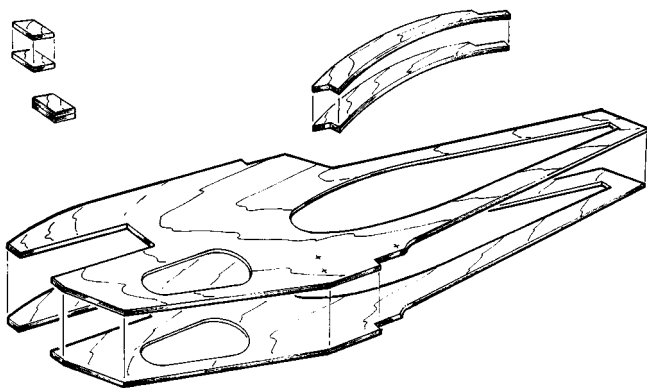

○ (1) Punch out the plywood die-cut parts. Use 30-minute epoxy to laminate the fuselage core, canopy frame & hump strap pads together. Make sure that the center marks for the landing gear bolt location and balance point are facing outward.

NOTE: The airfoil shape that you punched out will be used for the wing tips in step 29. The front of the engine cut-out, as well as the ellipse from the wig tips, is not needed during construction. You may save these for later use as scrap.

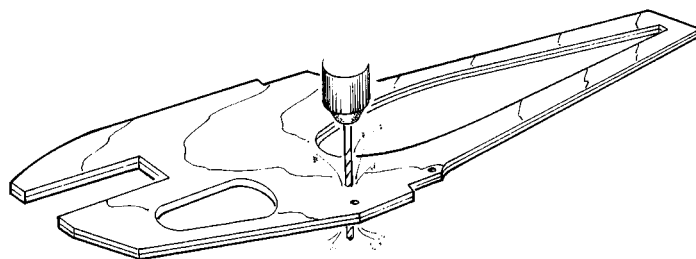

○ (2) Drill a 5/32" diameter hole through the laminated fuselage core at the two landing gear center marks and also at the balance point.

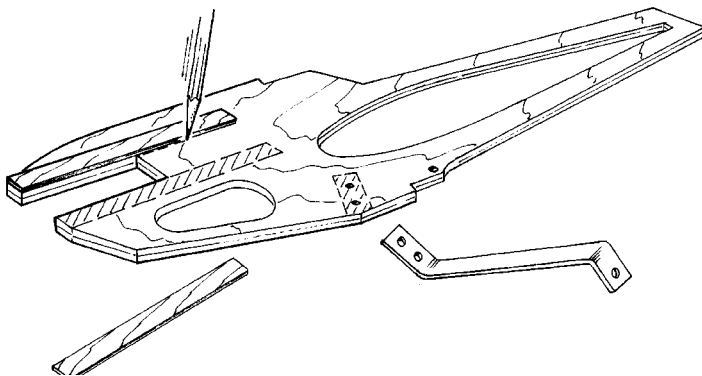

○ (3) Using the 1/8" x 1/2" x 6" plywood engine doublers and the aluminum landing gear struts, mark the area on the fuselage core as shown. When installing the side sheeting, do **NOT** apply glue to the areas you just marked. Be sure to mark both sides of the assembly.

7

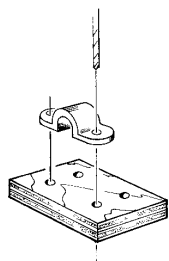

○ (4) Using a hump strap as a template, drill four 1/16" diameter holes through the two hump strap pads. Set these pads aside for now.

1/4" Balsa SPACER BLOCKS

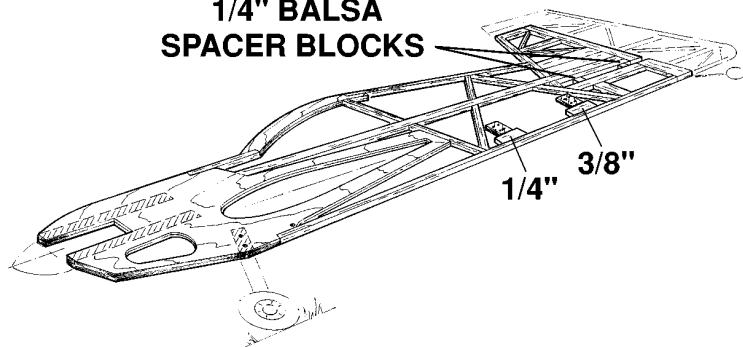

Note: Use only **one** of the six 1/4" x 3/8" x 36" balsa sticks to build the fin and rudder.

○ (5) Pin the entire fuselage portion of the plan over your building board and cover the plan with wax paper. Build the fuselage and fin over the plan as shown. Glue the hump strap pads to scrap balsa shims as shown. Without glue, use 1/4" leftover balsa spacers to maintain stab slot width.

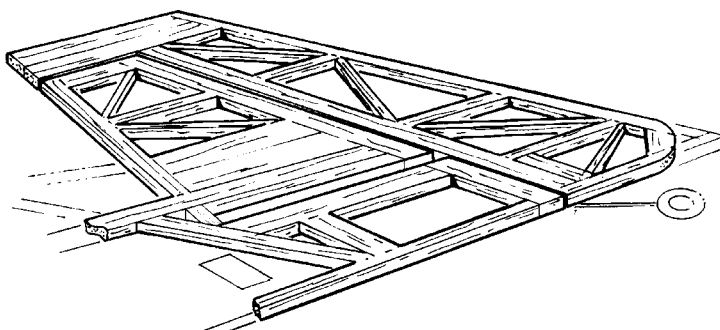

○ (6) Build the rudder over the plan as shown.

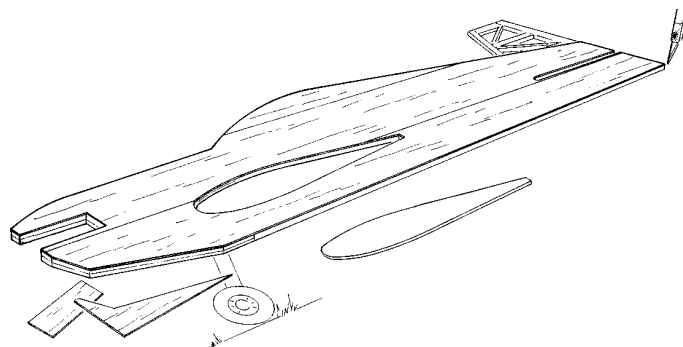

○ (7) Glue two 3/32" x 3" x 36" balsa sheets to one side of the fuselage frame. Make sure that you do **NOT** glue the sheeting to the areas that you marked in step 3. Trim the sheeting around the perimeter and the wing cutout. Use leftover balsa trimmed from the aft end of the fuse to fill in the top of the canopy area.

8

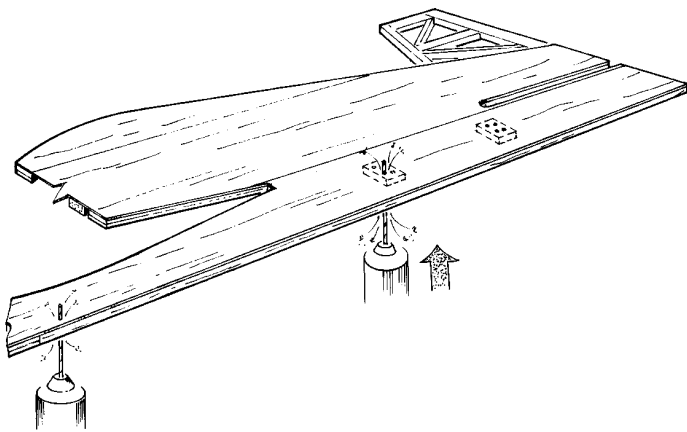

○ (8) Take the fuselage off the building board. Drill 1/16" diameter holes through the balsa sheeting using the four pilot holes in each hump strap pad and the balance hole as guides. Drill 5/32" holes through the balsa skin for the landing gear. These will help you position the landing gear later. Refer to the plan for the length of the stab slot and then measure and cut the opening.

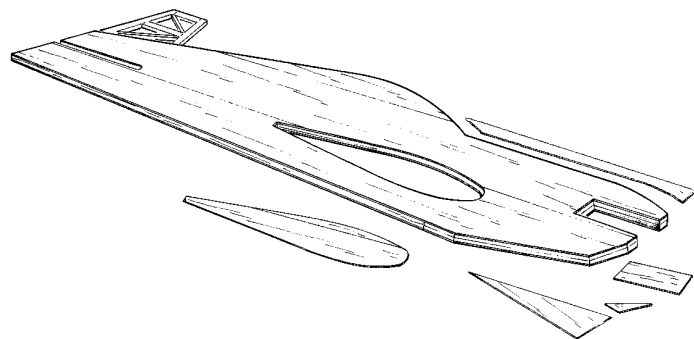

○ (9) Flip the fuselage over and sheet the open side using (2) 3/32" x 3" x 36" balsa sheets. Don't glue the marked areas from step 3. Trim the perimeter and wing opening as you did in step 7.

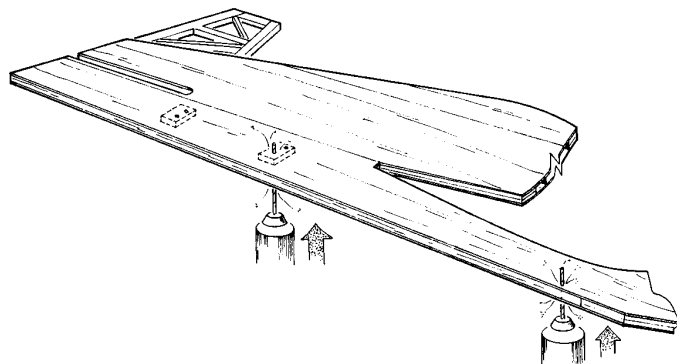

○ (10) Drill 1/16" diameter holes through the balsa sheeting using only the **front two** pilot holes in each hump strap pad and the balance hole. Drill through the landing gear holes with a 5/32" bit.

9

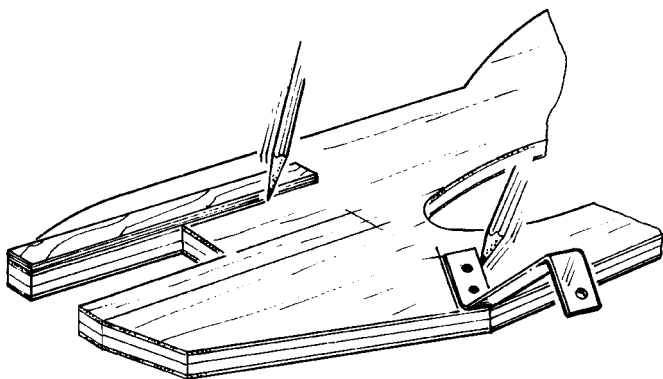

○ (11) Using the engine mount doublers and a landing gear strut as templates, mark the balsa to be trimmed from the unglued area of the fuselage core. Mark both sides of the fuselage.

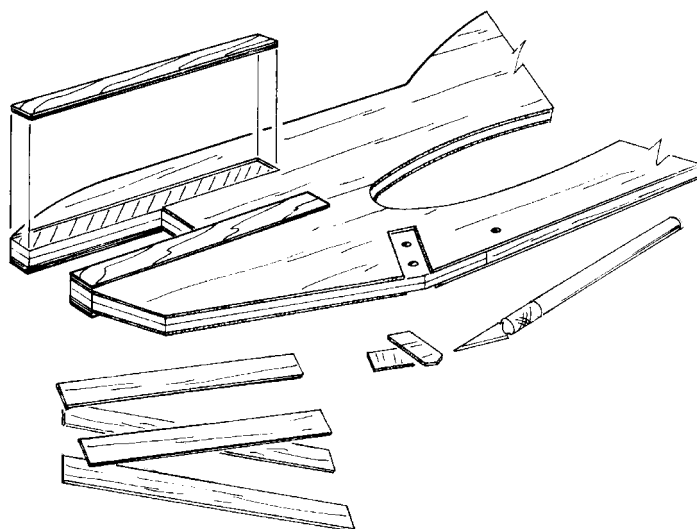

○ (12) Trim the balsa from the unglued areas on both sides of the fuselage. Use 30-minute epoxy to glue the plywood engine doublers onto the plywood skeleton on both sides.

This completes the basic construction of the fuselage. Round the perimeter and flat sand the sides. Put the fuselage aside for now and move on to the horizontal stabilizer.

10

BUILD THE HORIZONTAL STABILIZER AND ELEVATORS

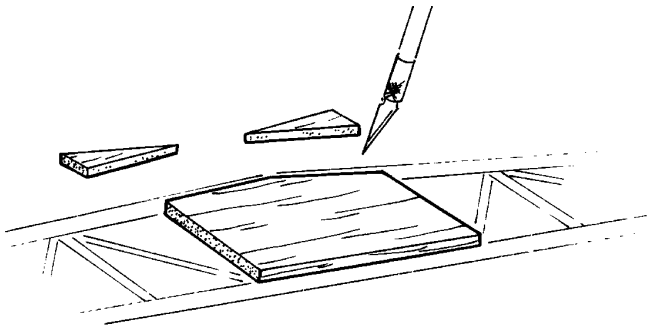

○ (13) Pin the horizontal stabilizer and the elevators portion of the plan to the building board. Cover this portion with wax paper. Trim the 1/4" x 3" x 4-3/8" balsa stabilizer platform as shown. Use the plan for the correct outline.

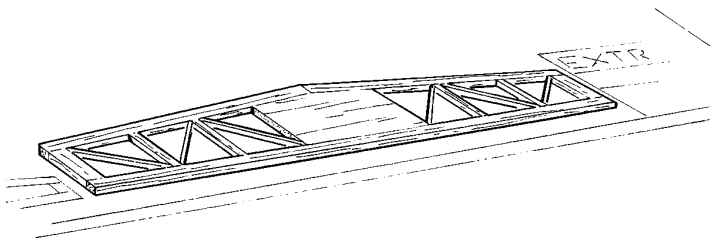

○ (14) Assemble the stabilizer over the plan using the materials specified on the plans.

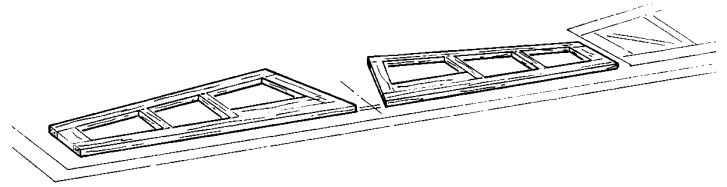

○ (15) Assemble the elevators over the plan as shown.

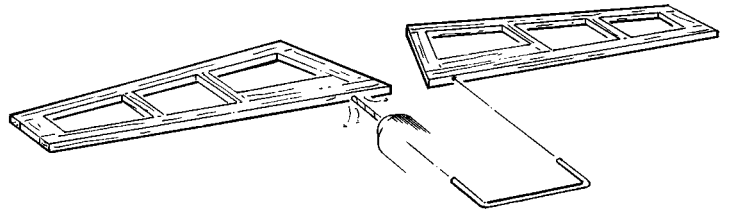

○ (16) Locate the elevator joiner wire and drill a 1/8" diameter hole in each elevator at the location shown on the plan.

11

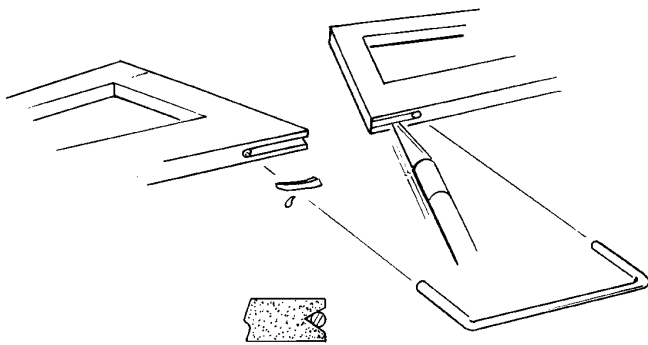

○ (17) Carve out the joiner wire clearance on each elevator as shown. Test fit the wire joiner until the fit is as shown.

This completes the stab and elevators. Put them aside for now and let's move on to the wing construction.

BUILD THE WING AND AILERONS

Note: The wing is built over the plan, with the **bottom** of the wing facing up.

Refer to the following illustration when performing the next 3 steps. Pin the wing portion of the plan to the building board. Cover the plan with wax paper.

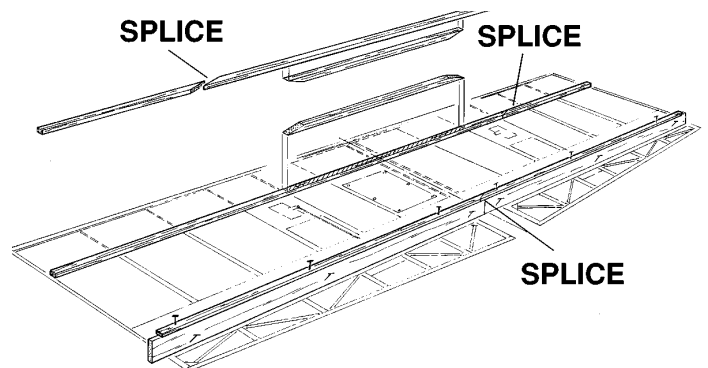

○ (1) Use the 1/8" x 3/8" x 24" balsa sticks to make the 44" trailing edge by joining them with a diagonal splice at the centerline.

○ (2) Pin two 1/4" x 1-1/8" x 24" balsa leading edge sticks over the wing plan to create a temporary trailing edge fixture. **These fixture sticks are used later to make the wing leading edge.** Cover the fixture with wax paper. Then pin the 1/8" x 3/8" x 44" trailing edge to the top edge.

○ (3) Make two 44" wing spars by cutting and joining 1/4" x 3/8" x 36" balsa sticks using a diagonal splice at one end. Cut the 1/4" x 3/8" x 30" balsa spar doubler in half to make two 15" sticks. Bevel both ends of spar doublers and glue them to the spars where shown on the plan. Pin the bottom spar assembly into position over the plan.

Important: When positioning the spars, be sure that the top and bottom splices are at **opposite ends** of the wing.

12

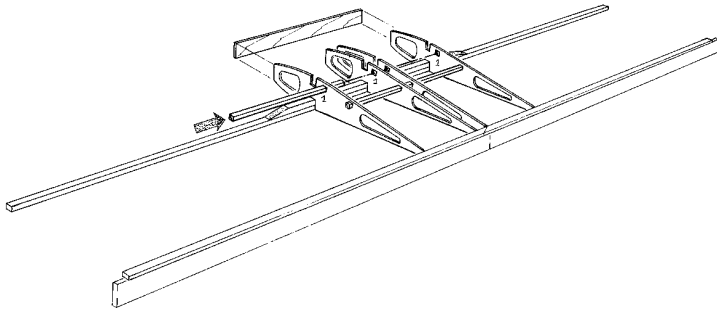

○ (4) Glue the four #1 ribs onto the bottom spar and trailing edge over the locations shown on the plan. Make sure that the 1/4" square holes for the servo mounting rails are **up** as shown and that the ribs are centered on the trailing edge.

Glue the 1/8" x 7/8" x 8-1/4" ply leading edge doubler onto the front of the #1 ribs.

Cut the 1/4" x 15" hardwood servo mounting rails to 8-1/4". Save the leftover pieces for aileron servo mounting. Slide a servo mounting rail through the front and back square holes as shown and glue them securely into position.

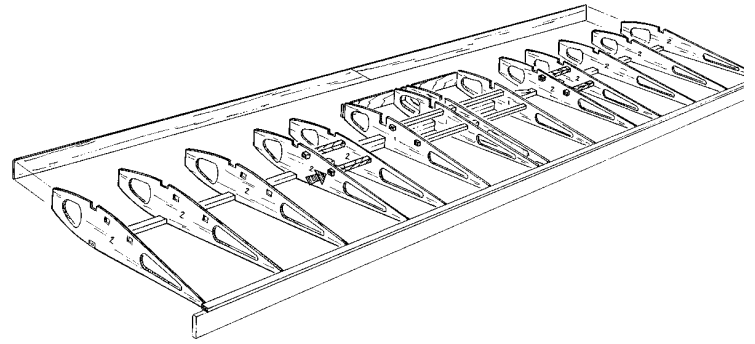

○ (5) Glue all of the #2 ribs onto the bottom spar and trailing edge. Once again make sure all of the 1/4" square holes are at the top. Cut and glue four 1/4" square hardwood aileron servo mounting rails into the square holes in the proper ribs.

Splice two 3/32" x 7/8" x 24" balsa sheets together with a diagonal cut to make the sub-leading edge. Glue the sub-leading edge to the front of all #2 ribs and to the leading edge doubler.

13

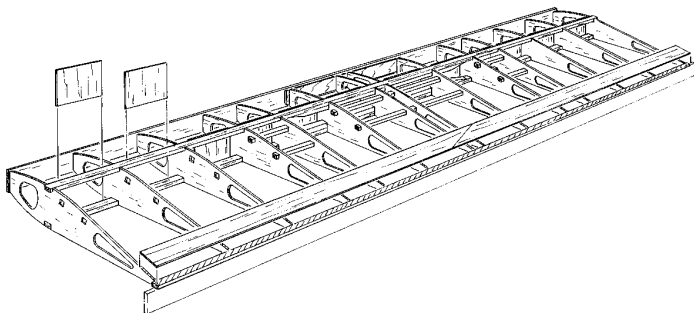

○ (6) Glue the top spar assembly into the notches in all of the wing ribs.

Cut and glue the 1/16" x 3" balsa shear webs securely to the front of the spars.

Diagonally splice the two 3/32" x 7/8" x 24" balsa trailing edge sheets at the centerline. Glue the trailing edge sheeting to the ribs and to the 1/8" x 3/8" balsa trailing edge.



SAND FLUSH

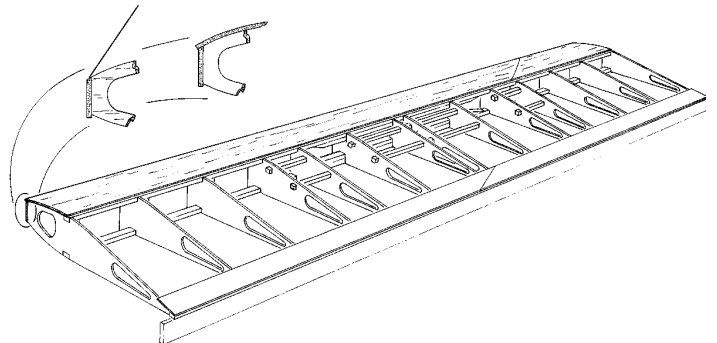

○ (7) Bevel the sub-leading edge with a long sanding block so that it is flush with the tops of all wing ribs as shown.

Refer to the plan and sketch above, then use three 3/32" x 3" x 36" balsa sheets, spliced diagonally, to make **two** 44" long leading edge sheets. *Set one 44" sheet aside for the time being.*

Glue a leading edge sheet to the ribs, beveled sub-leading edge and upper spar. Position the splice as shown on the plan.

Note: The sheeting will only cover the front half of the spar.

14

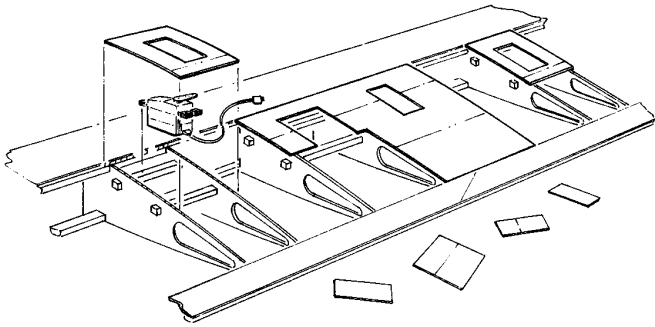

○ (8) Temporarily position a servo and cut $3/32$ " balsa sheeting to fit the two aileron servo areas and the center section. Leftover sheeting can be used along with a $3/32$ " x 3" x 36" sheet supplied for this purpose. Use the plan to determine the hatch location.

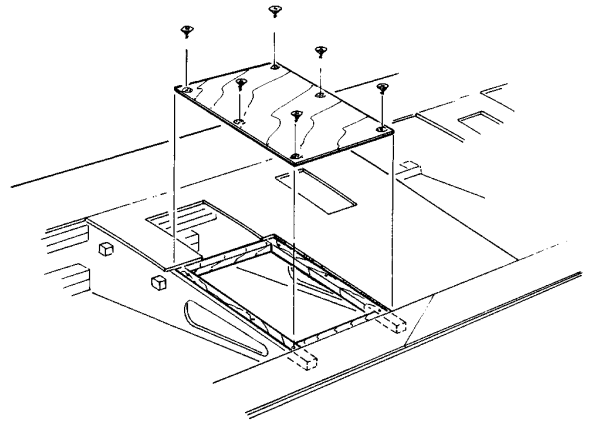

○ (9) Cut, fit and glue $1/4$ " square, hard balsa hatch mount rails between the ribs as shown on the plan. Trim the $1/16$ " x $3-1/4$ " x $5-1/4$ " plywood hatch cover to fit as shown. See the plan for the correct location of the six #2 x $3/8$ " flat head hatch screws. Drill and countersink the six screw holes.

Drill $1/32$ " pilot holes into the hatch mount rails. Test fit the hatch to the wing using all six screws. Remove the hatch when you are satisfied with the fit. Apply a couple of drops of thin CA to each screw hole in the mounting rails to harden the balsa.

15

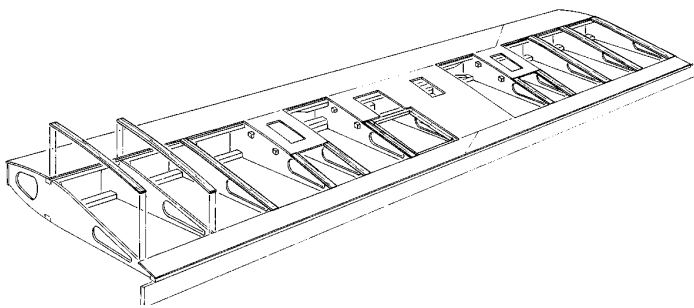

○ (10) Trim and glue the $3/32$ " x $1/4$ " balsa capstrips to the wing ribs.

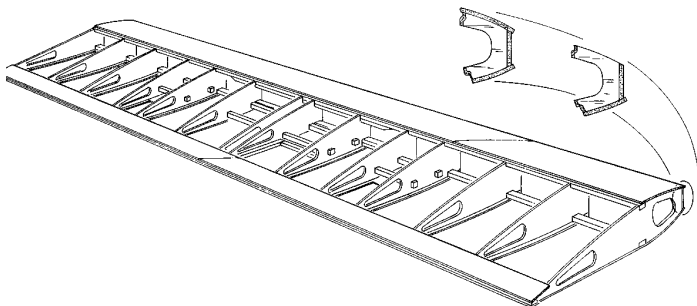

○ (11) Remove the wing from the building board and turn it over. The trailing edge fixture is no longer needed to support the TE of

the wing. Sand the sub-leading edge so that it's flush with the tops of all ribs as shown. Glue the second $3/32$ " x 3" x 44" leading edge sheet to the ribs, beveled sub-leading edge and spar.

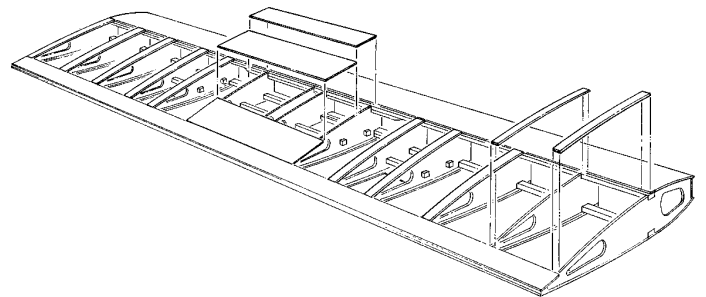

○ (12) Cut, fit and glue the $3/32$ " x 3" balsa wing center sheeting and $3/32$ " x $1/4$ " balsa capstrips to the wing ribs.

16

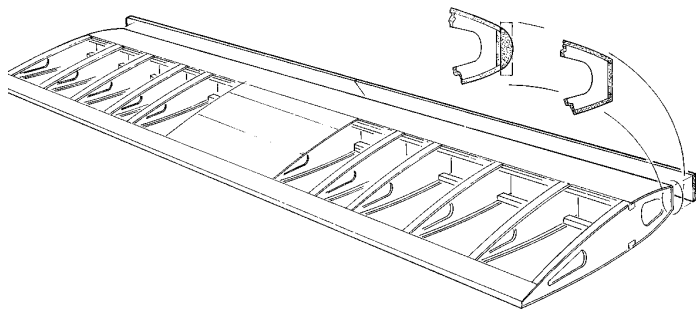

○ (13) Sand the top and bottom leading edge sheeting until it is flush with the front face of the sub-leading edge, as shown.

Diagonally splice, at the wing centerline, the two 1/4" x 1-1/8" x 24" balsa leading edge pieces. *You used these pieces as a trailing edge fixture earlier in the wing construction.* Glue them to the sub-leading edge

Carve and sand the leading edge to shape as shown.

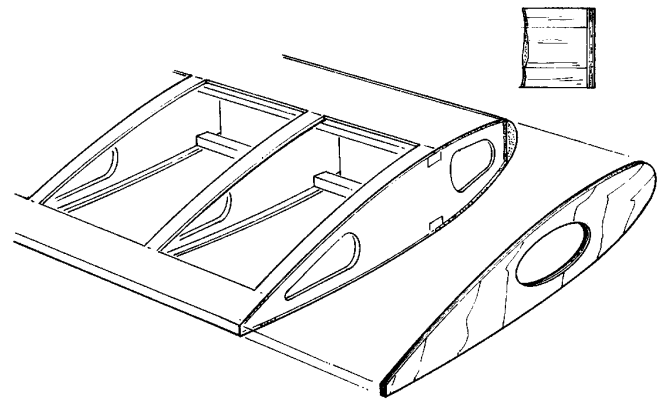

○ (14) Sand both ends of the wing smooth. Glue the die-cut plywood wing tips onto the sanded wing ends.

Sand the edge of the airfoil to insure the wing tip is flush with the wing.

17

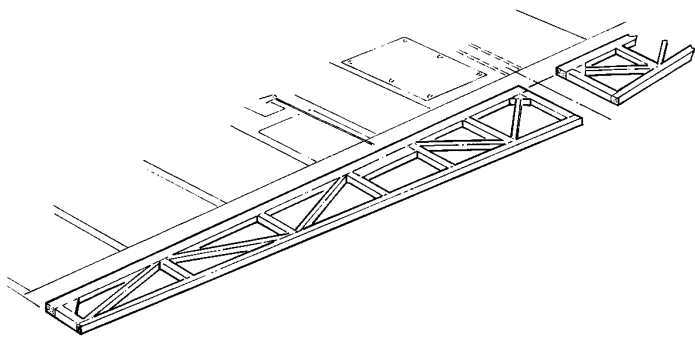

○ (15) With the wax paper still positioned over the plan, build both ailerons using the sticks specified on the plan.

○ (16) Draw a centerline on the trailing edge of the fin, stabilizer and wing. Refer to the plans, then mark and cut hinge slots.

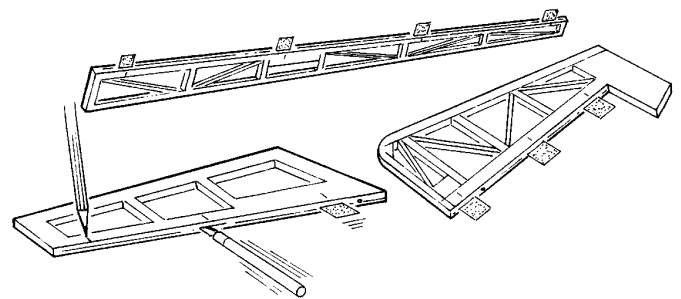

○ (17) Mark and cut **matching** hinge slots on all control surfaces. A #11 blade in a hobby knife works well for cutting the slots.

Test fit (**do not glue**) the control surfaces to the stab, fin and wing.

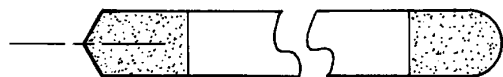

○ (18) When you are satisfied with the fit, remove the hinges and bevel the **leading edge** of the ailerons, elevators and rudder. Round the remaining perimeter edges of the rudder, fin, stab, ailerons and elevators.

18

FINAL ASSEMBLY

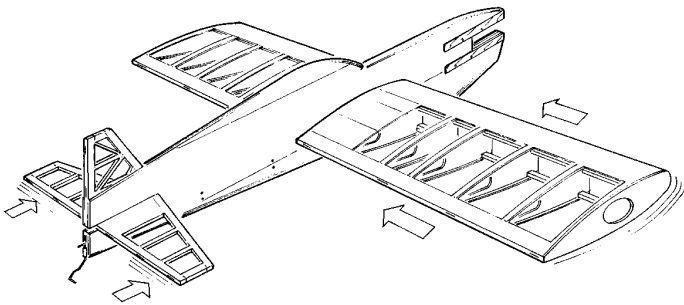

○ (1) Draw a centerline from the leading edge to trailing edge on the top of the wing and stab. Draw a parallel line 1/4" on each side of the center lines for reference, so you will know when the wing and stab are centered in the fuse. Slide the wing and horizontal stab into the fuselage. Make sure the fuselage is centered between the reference lines.

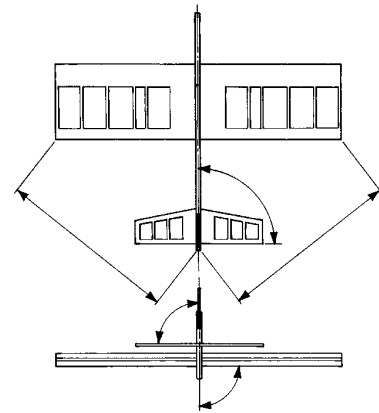

○ (2) Carefully check the alignment of the wing and stab to the fuselage as shown. Permanently glue the wing and stab to the fuselage with 30-minute epoxy.

After the epoxy has cured, fill any gaps with a mixture of micro balloons and epoxy.

Cut the slot for the tail gear bracket in the aft of the fuse and check its fit. Hold the rudder in position and mark the location of the tail gear steering arm. Drill a 1/8" diameter hole into the rudder at the marked location. Notch the rudder to accept the protruding tail gear bracket and wire.

19

Balance the airplane laterally

Note: Do not confuse this procedure with "checking the C.G." or "balancing the airplane fore and aft." That very important step will be covered later in the manual.

1. Temporarily install the engine (with muffler), landing gear, radio equipment and battery.
2. With the wing level, lift the model by the engine propeller shaft and the fin (this may require two people). Do this several times.
3. If one wing always drops when you lift the model, it means that side is heavy. Balance the airplane by gluing a weight to the **inside** of the other wing tip.

NOTE: An airplane that has been laterally balanced will track better in loops and other maneuvers.

COVERING AND FINISHING

We recommend using a light-weight film covering material such as **TowerKote™** to finish your Extra Special 40. Apply the film following the manufacturer's instructions using the sequence we suggest for best results.

REPAIRING SURFACE DINGS

Many surface blemishes on a framed model are caused by bumps and balsa chips on the work surface. This type of ding is best repaired by applying a drop or two of window cleaner or tap water to the blemish, then running a **hot** sealing iron over the spot to expand the wood fibers. After the surface has dried, sand the *expanded* area smooth.

FINAL SANDING

Fill any large scuffs or dings. Then sand the entire structure with progressively finer grades of sandpaper, ending with 320-grit.

COVER THE STRUCTURE WITH TOWERKOTE

The Extra Special .40 does not require any painting to obtain the scheme shown on the box, as all of the finish is TowerKote™.

Make sure the structure is smoothly sanded with **320-grit** sandpaper. Remove all dust from the structure with a vacuum cleaner and **Top Flite® Tack Cloth** so the TowerKote will stick well. Cover the aircraft with TowerKote using the sequence that follows. Make sure the TowerKote is thoroughly stuck to the structure and all edges are sealed. Use a **Top Flite Hot Sock™** on your covering iron to avoid scratching the finish.

20

When covering areas that involve sharp junctions, like the tail section or around the root end of the wing, cut narrow strips (1/4" to 3/8") and apply them in the corners **before** covering the major surfaces. The larger pieces of TowerKote will overlap and capture these smaller pieces. This technique also bypasses the need to cut the TowerKote in these areas after it has been **applied**. **DO NOT, under any** circumstances, attempt to cut the covering material after it has been applied to the fin and stab, except around the leading and trailing edges.

RECOMMENDED COVERING SEQUENCE

- 1. Tail junction strips as described above
- 2. Wing/fuse junction
- 3. TE surfaces of wing
- 4. Bottom of left and right wing panels
- 5. Top of left and right wing panel and wing tips
- 6. Fuse sides (overlap at top and bottom)
- 7. Stab bottom
- 8. Stab top
- 9. Fin left and right side
- 10. Rudder left and right side
- 11. Bottom of elevators
- 12. Top of elevators
- 13. Ends of ailerons
- 14. Bottom of ailerons
- 15. Top of ailerons
- 16. Hatch cover

○ (2) Install the elevator and ailerons using hinges. When satisfied with the fit, place a few drops of CA glue into **both** sides of each hinge. After the CA has cured, move each control surface to loosen them up.

Put a dab of petroleum jelly on the top and bottom of the tail gear bracket where the wire passed through it. Pack the hole in the rudder with 30-minute epoxy. Then, fit the rudder in position with hinges. Apply thin CA to both sides of each hinge.

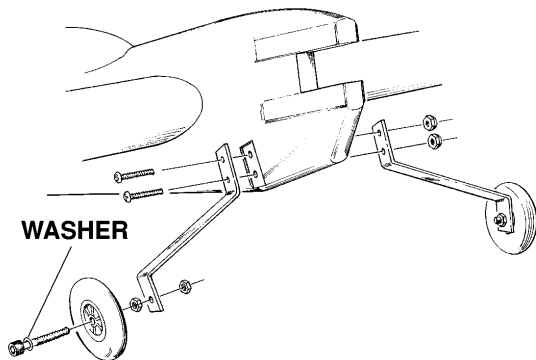

○ (3) Poke two holes through the covering at the bolt locations for the landing gear struts. Bolt the struts to the fuselage, using two 6-32 x 3/4" pan head screws and two 6-32 lock nuts.

Install the wheels on the landing gear struts using two 8-32 x 1-1/4" bolts, two #8 flat washers and four hex nuts.

FINAL HOOKUPS AND CHECKS

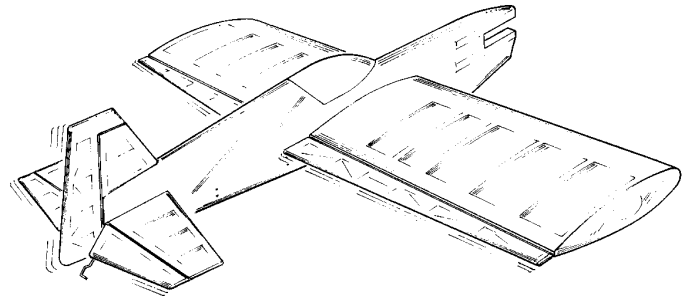

○ (1) Lay the control surfaces over the plans for reference and mark the location of the hinge slots.

Cut through the covering at each hinge slot on the control surface and its mating part.

Roughen the elevator joiner wire with coarse sandpaper. Pack 30-minute epoxy into the holes in the elevator halves with a toothpick. Insert the joiner wire into both elevators and place the assembly on a flat surface to cure. Be sure the elevator leading edge is straight before the epoxy cures.

21

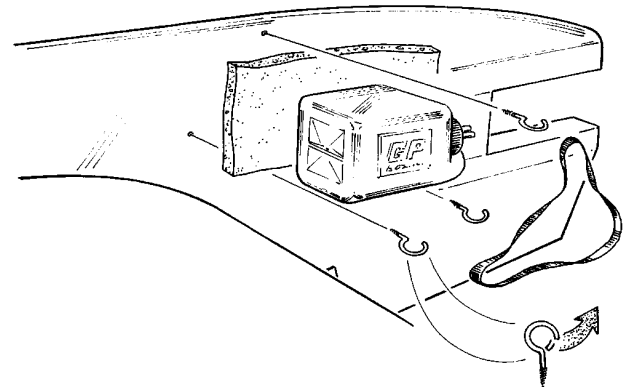

○ (4) Assemble your 4 or 6 oz. fuel tank.

Open the three "closed loop" screw eyes to make hooks as shown. Locate the position of the hooks and screw them into the fuselage. Place a piece of 1/4" foam between the fuselage side and the tank and rubber band the tank in place as shown. You may want to use three rubber bands to secure the tank to the aircraft.

○ (5) Install a spinner on your engine. Position the engine so the back edge of the spinner is approximately 3/32" in front of the fuselage. Mark the location of the engine mounting holes.

22

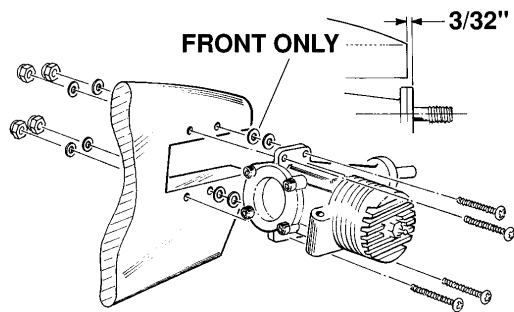

○ (6) Drill four 1/8" holes through the ply engine mounts. Use two #6 washers between the engine and the mounts under the two front holes. This will provide the required 2 degrees of right thrust. Secure the engine with four 4-40 x 1" pan head bolts, locknuts and washers.

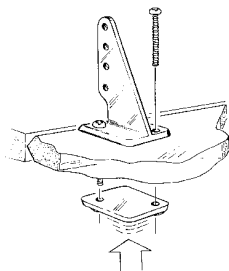

○ (7) Install all five control horns. Drill the required 3/32" holes, using a control horn as a locating template. Secure the horns with two 2-56 x 5/8" machine screws. Trim off the excess threaded portion of the screws after tightening.

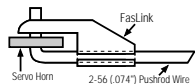

○ (10) Insert the pushrod end and secure it in position with a nylon Faslink. Bend the throttle pushrod to fit your engine throttle arm.

Thread the antenna wire out along the fuselage and let it trail off behind the rudder.

BALANCE YOUR MODEL

NOTE: This section is VERY important and must NOT be omitted! A model that is not properly balanced will be unstable and possibly unflyable.

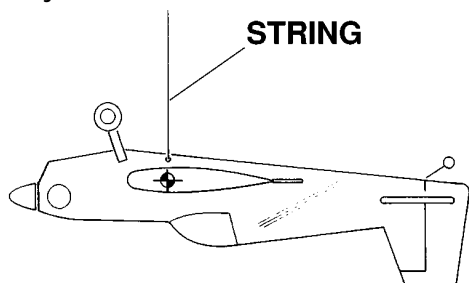

○ (1) Hang the model by a string threaded through the balance hole on the bottom of the model. This is the balance point at

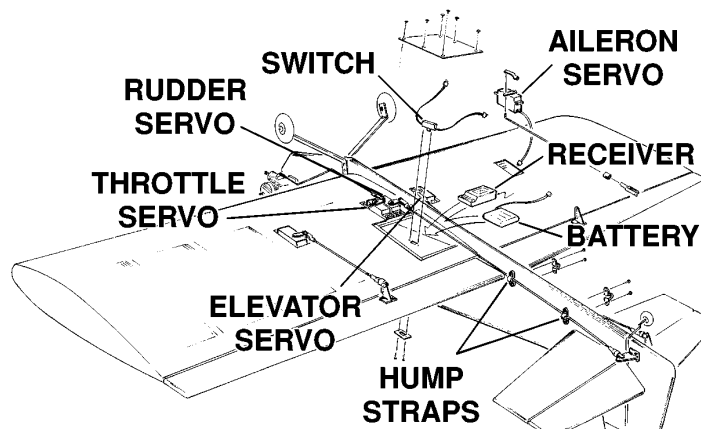

○ (8) Install the radio receiver, battery, switch and servos. Cut the 35" pushrods to fit for the rudder and elevator. Make the aileron pushrods from the excess length trimmed from the elevator and rudder pushrods. Install the nylon hump straps with #2 x 3/8" screws. Slide a silicone retainer onto each nylon clevis. Screw a clevis onto each pushrod about 14 turns. Slide the pushrods into position, clip the clevises onto the horns and slide the silicone retainer over the clevis to lock in place.

○ (9) Center the servo horns by turning on the radio and centering the trim switches. Mark the position on the pushrod where the pushrod intersects the servo horn. Make a 90 degree bend on the mark. Cut off the excess wire about 3/8" above the bend. Enlarge the hole in the servo horn to 5/64".

which your model should balance for your first flights. Later, you may wish to experiment by shifting the balance up to **1/4" forward or back** to change the flying characteristics. Moving the balance **forward** may improve the smoothness and arrow-like tracking, but it may then require more speed for takeoff and make it more difficult to slow down for landing. Moving the balance **aft** makes the model **more agile** with a lighter and snappier feel. In any case, **please start at the location we recommend and do not at any time balance your model outside the recommended range.**

○ (2) With all equipment installed (ready to fly) and an **empty** fuel tank, lift the model at the balance point. If the tail drops when you lift, the model is "tail heavy" and you must move weight toward the nose to balance. If the nose drops, it's "nose heavy" and you must move weight toward the tail to balance. Try to balance the model by changing the position of the **receiver battery** and **receiver**. If this is not enough, you may need to add stick-on weights to the tail or a Great Planes spinner weight (GPMQ4645) to the nose.

CONTROL SURFACE THROWS

Control throw adjustment

○ (1) By moving the position of the clevis at the control horn **toward the outermost hole**, you will **decrease** the amount of throw of that control surface. Moving it **toward the control surface** will **increase** the amount of throw. If these adjustments don't accomplish the job, you may need to work with a combination of adjustments by also repositioning the pushrod at the servo end. Moving the pushrod toward the splined shaft on the servo will decrease the control surface throw — outward will increase it.

We recommend the following control surface throws as a **starting point**:

| | High Rate | Low Rate |
|------------------|---|------------------------------------|
| ELEVATOR: | 7/8" up [22mm] 7/8" down [22mm] | 1/2" up [13mm] 1/2" down [13mm] |
| RUDDER: | 1-3/4" right [44.5mm] 1-3/4" left [44.5mm] | Same as high rates |
| AILERONS: | 1" up [25.4mm] 1" down [25.4mm] | 5/8" up [16mm] 5/8" down [16mm] |

NOTE: Throws are measured at the **widest part** of the elevators, rudder and ailerons. If your radio does not have dual rates, set the control throws halfway between the specified high and low rates.

○ (2). Make sure the control surfaces move in the proper direction as illustrated in the following sketch.

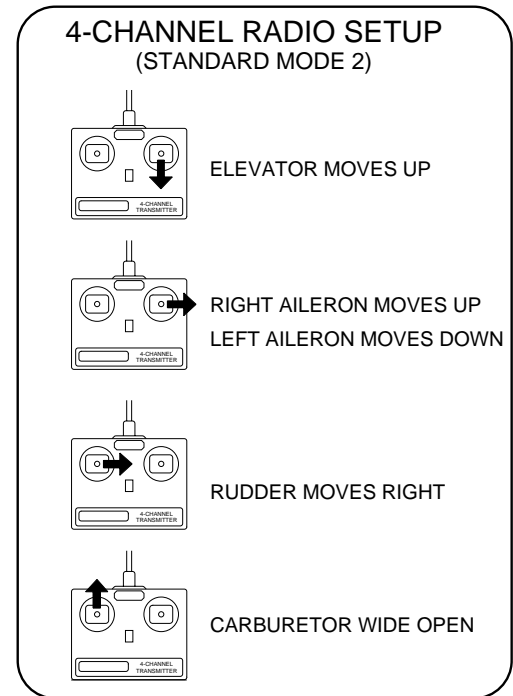

25

PREFLIGHT

Balance the prop

Balance your propellers carefully before flying. An unbalanced prop is the single most significant cause of damaging vibration. Not only will engine mounting screws and bolts vibrate out, possibly with disastrous effect, but vibration will also damage your radio receiver and battery.

Charge the batteries

Follow the battery charging procedures in your radio instruction manual. You should **always** charge your transmitter and receiver batteries the night before you go flying and at other times as recommended by the radio manufacturer.

Ground check the model

If you are not thoroughly familiar with the operation of R/C models, ask an experienced modeler to check if you have installed the radio correctly and that all the control surfaces move in the correct direction. The engine operation also must be checked and the engine "broken-in" on the ground. **Follow the engine manufacturer's recommendations for break-in.** Check to make sure all screws remain tight, that the hinges are secure and that the prop is on tight.

Range check your radio

Whenever you fly, you need to check the operation of the radio before the first flight of the day. This means with the transmitter antenna collapsed and the receiver and transmitter on, you

should be able to walk at least 100 feet [30.5 meters] away from the model and still have control. Have someone stand by your model and, while you work the controls, tell you what the various control surfaces are doing.

Repeat this test **with the engine running** at various speeds, with an assistant holding the model. If the control surfaces are not always acting correctly, **do not fly!** Find and correct the problem first.

Failure to follow these safety precautions may result in severe injury to yourself and others.

Keep all engine fuel in a safe place, away from high heat, sparks or flames, as fuel is very flammable. Do not smoke near the engine or fuel; and remember that the engine exhaust gives off a great deal of deadly carbon monoxide. Therefore **do not run the engine in a closed room or garage.**

Get help from an experienced pilot when learning to adjust and operate engines.

Use safety glasses when starting or running engines.

Do not run the engine in an area of loose gravel or sand, as the propeller may throw such material in your face or eyes.

Keep your face and body as well as all spectators away from the plane of rotation of the propeller as you start and run the engine.

26

Keep items such as these away from the prop: loose clothing, shirt sleeves, ties, scarfs, long hair or loose objects (pencils, screw drivers) that may fall out of shirt or jacket pockets into the prop.

Use a "chicken stick" device or electric starter; follow instructions supplied with the starter or stick. Make certain the glow plug clip or connector is secure so that it will not pop off or otherwise get into the running propeller.

Make all engine adjustments from **behind** the rotating propeller.

The engine gets hot! Do not touch it during or after operation. Make sure fuel lines are in good condition so fuel will not leak onto a hot engine causing a fire.

To stop the engine, cut off the fuel supply by closing off the fuel line or follow the engine manufacturer's recommendations. Do not use hands, fingers or any body part to try to stop the engine. Do not throw anything into the prop of a running engine.

FLIGHT

The Tower Extra Special .40 is a great flying sport airplane that flies smoothly and predictably, yet is highly maneuverable. It does not, however, have the self-recovery characteristics of a primary R/C trainer; therefore, ***you must either have mastered the basics of R/C flying or obtained the assistance of a competent R/C pilot to help you with your first flights.***

Takeoff: If you have dual rates on your transmitter, set the switches to "high rate" for takeoff, especially when taking off in a crosswind. Although this model has excellent low speed characteristics, you should always build up as much speed as your runway will permit before lifting off, as this will give you a safety margin in case of a "flame-out." When you first advance the throttle and the tail begins to lift, the plane will start to turn left (a characteristic of all "tail draggers"). Be ready for this and correct by applying sufficient right rudder to hold it straight down the runway. The left-turning tendency will diminish as soon as the tail is up and the plane picks up speed. Be **sure** to allow the tail to come up. Don't hold the tail on the ground with too much up elevator, as the plane will become airborne prematurely and possibly stall. When the plane has sufficient flying speed, lift off by smoothly applying up elevator (don't "jerk" it off to a steep climb!) and climb out gradually.

Flying: We recommend that you take it easy with your Extra Special for the first several flights, gradually "getting acquainted" with this responsive sport plane as your engine gets fully broken-in. Add and practice one maneuver at a time, learning how she behaves in each. For ultra-smooth flying and most normal maneuvers, we recommend using the "low rate" settings as listed on page 25. "High rates" should be used for tearing up the sky, low level loops, snaps and spins and most quick response flying. Speed is the key to good knife-edge performance.

27

CAUTION (THIS APPLIES TO ALL R/C AIRPLANES): If, while flying, you notice any unusual sounds, such as a low-pitched "buzz," this may be an indication of control surface "flutter." Because flutter can quickly destroy components of your airplane, any time you detect flutter you must **immediately** cut the throttle and land the airplane! Check all servo grommets for deterioration (this will indicate which surface fluttered), and make sure all pushrod linkages are slop-free. If it fluttered once, it probably will flutter again under similar circumstances unless you can eliminate the slop or flexing in the linkages. Here are some things which can result in flutter: Excessive hinge gap; Not mounting control horns solidly; Sloppy fit of clevis pin in horn; Elasticity present in flexible plastic pushrods; Side-play of pushrod in guide tube caused by tight bends; Sloppy fit of Z-bend in servo arm; Insufficient glue used when gluing in the elevator joiner wire or aileron torque rod; Excessive flexing of aileron, caused by using too soft balsa aileron; Excessive "play" or "backlash" in servo gears; and Insecure servo mounting.

Landing: When it's time to land, fly a normal landing pattern and make your final approach into the wind. For your first landings, plan to land slightly faster than stall speed and on all three wheels, as this is the easiest way to land your Extra Special.

We hope you enjoy your Tower Extra Special 40 and have a blast wowing the guys at the field.